

Hexdriver

Description

The Hexdriver IC includes 6 non inverted and current limited output stages with an open collector. Common thermal shutdown protects outputs against critical junction temperature.

Each output can sink 20 mA, parallel output operation is possible. The digital inputs have Schmitt-Trigger function with pull-up current sources to 5 V.

Features

- Six input comparators with Schmitt-Trigger characteristic
- Input clamping current capability to ± 10 mA
- Integrated protection cells (EMC, ESD, RF) dedicated to all input stages
- Common shutdown by junction temperature monitor
- Low voltage reset with hysteresis
- ESD protection to human body model: ± 2000 V ($C = 100$ pF, $R = 1.5$ k Ω)
- Output stages:
 - Short circuit protected with diode
 - Load dump protected @ 1 k Ω
 - No crosstalk on adjacent channels
 - Clamping current @ -2 mA
 - Jump start possible

Block Diagram

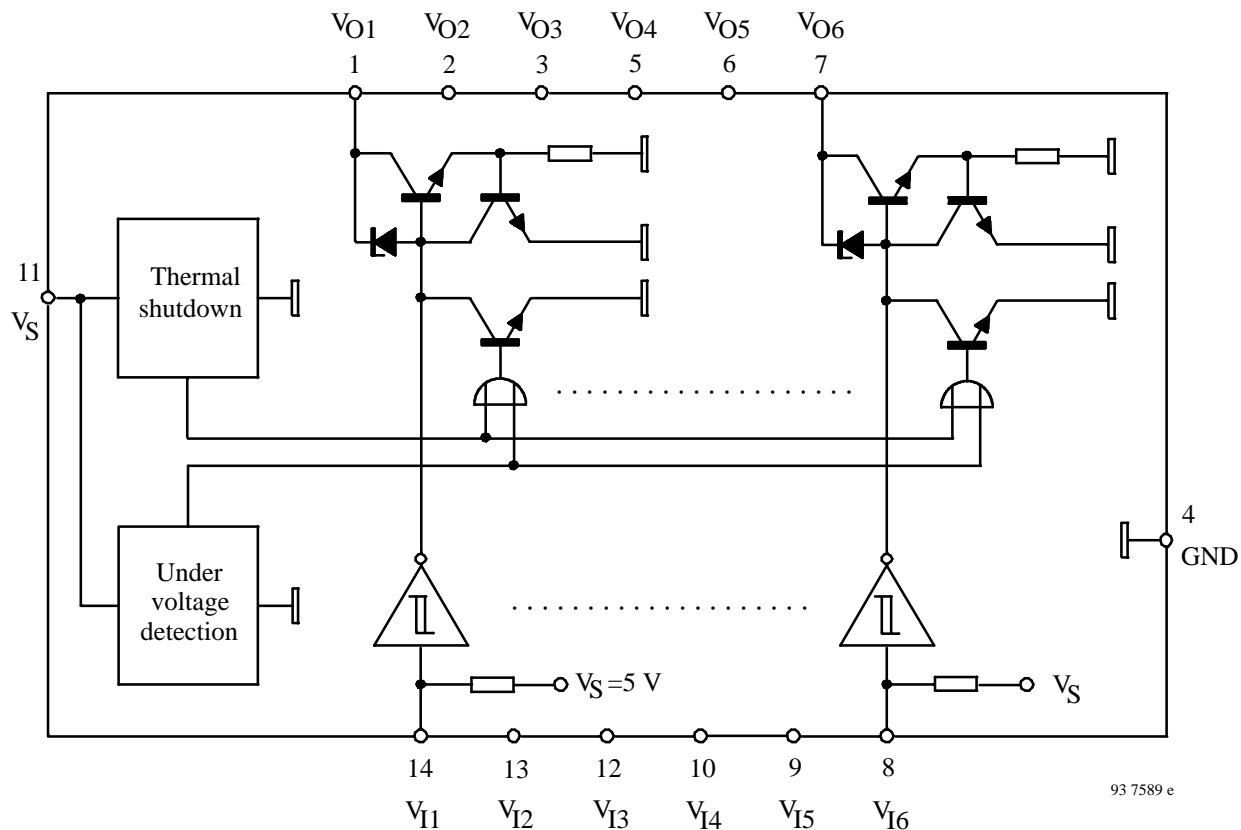

Figure 1.

U6805B-FP

Pin Description

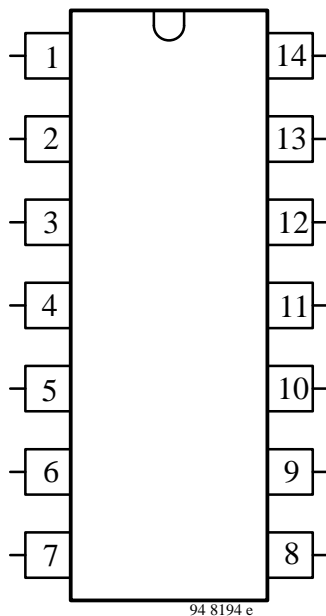

Figure 2. Pinning

Pin	Symbol	Function
1	V _{O1}	Output 1
2	V _{O2}	Output 2
3	V _{O3}	Output 3
4	GND	Ground
5	V _{O4}	Output 4
6	V _{O5}	Output 5
7	V _{O6}	Output 6
8	V _{I6}	Input 6
9	V _{I5}	Input 5
10	V _{I4}	Input 4
11	V _S	Supply voltage, 5 V
12	V _{I3}	Input 3
13	V _{I2}	Input 2
14	V _{I1}	Input 1

Basic Circuitry

Integrated circuit, U6805B, requires a stabilized supply voltage ($V_S = 5 \text{ V} \pm 5\%$) to comply with its electrical characteristics. An external buffer capacitor of $C = 100 \text{ nF}$ value is recommended. An integrated 14 V Z diode between V_S and ground protects the supply pin.

All input stages are provided with an integrated 250 k Ω pull-up resistor and can be directly connected to a microcontroller.

All output stages are open collectors each capable of sinking 20 mA. Recommended external components:

Pull-up resistor, $R = 1 \text{ k}\Omega$

Capacitor to GND, $C = 470 \text{ pF}$, see figure 3

Functional Description

General

ON state: Low level at the input stage activates the corresponding output stage.

OFF state: The internal pull-up resistor gives high level to the input comparator and deactivates the output stage.

7 V Z-diodes between each input pin and GND are capable of $\pm 10 \text{ mA}$ clamping currents without crosstalk on adjacent input stages.

A total clamping current of $\pm 30 \text{ mA}$ should be observed with respect to the power dissipation.

Current Limitation of the Output Stages and Overtemperature Shut-down

A temperature dependent current limitation between 25 and 100 mA protects the stages during a short. Additionally the chip temperature is monitored. For $T_{\text{chip}} > 148^\circ\text{C}$ all outputs are disabled and automatically enabled with a hysteresis of $\Delta T_{\text{chip}} > 5 \text{ K}$.

Transients and Load Dump

An integrated 28 V Z-diode protects each output stage against transients and load dump (Schaffner pulses). With the help of external 1 k Ω resistor, the output transistor is capable of the corresponding current which flows during each of these conditions. Apart from that, outputs are short circuit and overload protected.

Low Voltage Detection

When supply voltage is switched on, a power on reset pulse is generated internally, which disables all output stages until a defined supply voltage level is reached. The low voltage detection is provided with a hysteresis of $V_{\text{hyst}} = 0.5 \text{ V}$ typically.

Absolute Maximum Ratings

Parameters	Symbol	Value	Unit
Supply voltage range	V_S	4.75 to 5.25	V
Ambient temperature range	T_{amb}	-40 to +125	°C
Storage temperature range	T_{stg}	-50 to +150	°C
Maximum junction temperature	T_j	+150	°C

Thermal Resistance

Parameters	Symbol	Value	Unit
Junction ambient	R_{thJA}	120	K/W

Electrical Characteristics

$V_S = 5\text{ V} \pm 5\%$, $T_{amb} = 25^\circ\text{C}$, reference point pin 4 (GND), unless otherwise specified, see figure 1.

Parameters	Test Conditions / Pins	Symbol	Min.	Typ.	Max.	Unit
Supply Pin 11						
Supply voltage		V_S	4.75		5.25	V
Supply current:						
Inputs open		I_S	0.8		3.2	mA
Inputs closed		I_S	7		13	mA
Low voltage detection threshold:						
ON		$V_{TH(ON)}$	3.7		4.6	V
OFF		$V_{TH(OFF)}$	3.0		3.8	V
Low voltage hysteresis		V_{hyst}	0.55		1.05	V
Temperature shut down		T_{Chip}	140		149	°C
Temperature shut-down hysteresis		T_{hyst}	5			°C
Inputs Pins 8, 9, 10, 12, 13 and 14						
Z-diode protection voltage		V_I	6.7		8.5	V
Z-diode clamping current		I_I			± 10	mA
Pull-up resistor		R_I	170	250	305	k Ω
Switching threshold:						
OFF		V_I		3.3		V
ON		V_I		1.8		V
Hysteresis		V_{hyst}		1.5		V
Outputs Pins 1, 2, 3, 5, 6 and 7						
Z-diode protection voltage		V_O	26.5			V
Integrated capacitor				5		pF
Leakage current		I_{Leak}			2.5	μA
Saturation voltage ($I = 20\text{ mA}$)		V_{Sat}			0.8	V

U6805B-FP

Parameters	Test Conditions / Pins	Symbol	Min.	Typ.	Max.	Unit
Current limitation		I_{limit}	25			mA
Propagation delay (470 pF, 1 kΩ, 20 V)		t_d			5	μs

Application Circuit

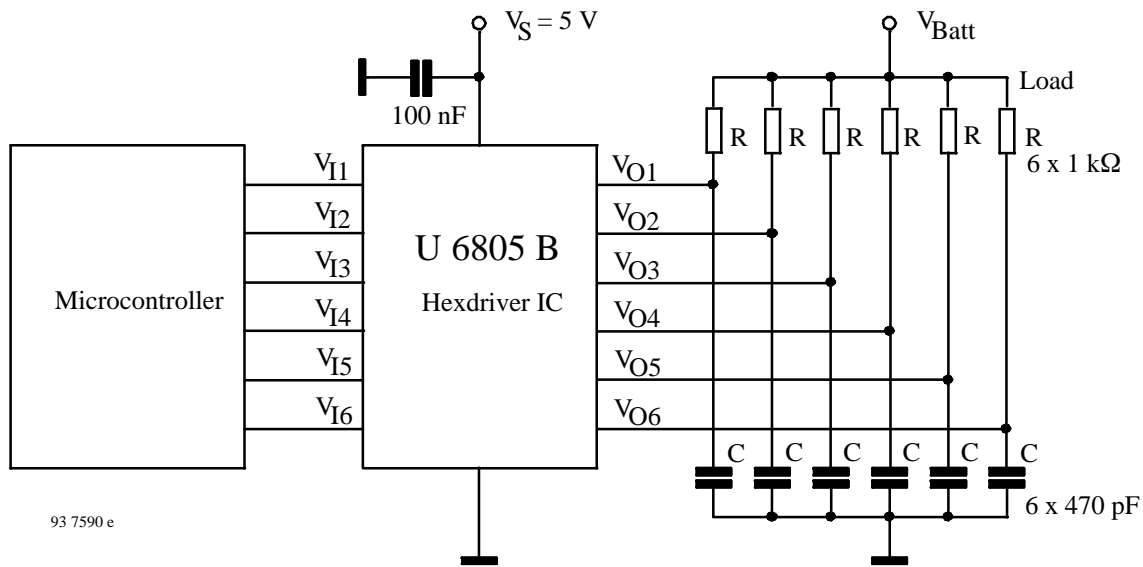
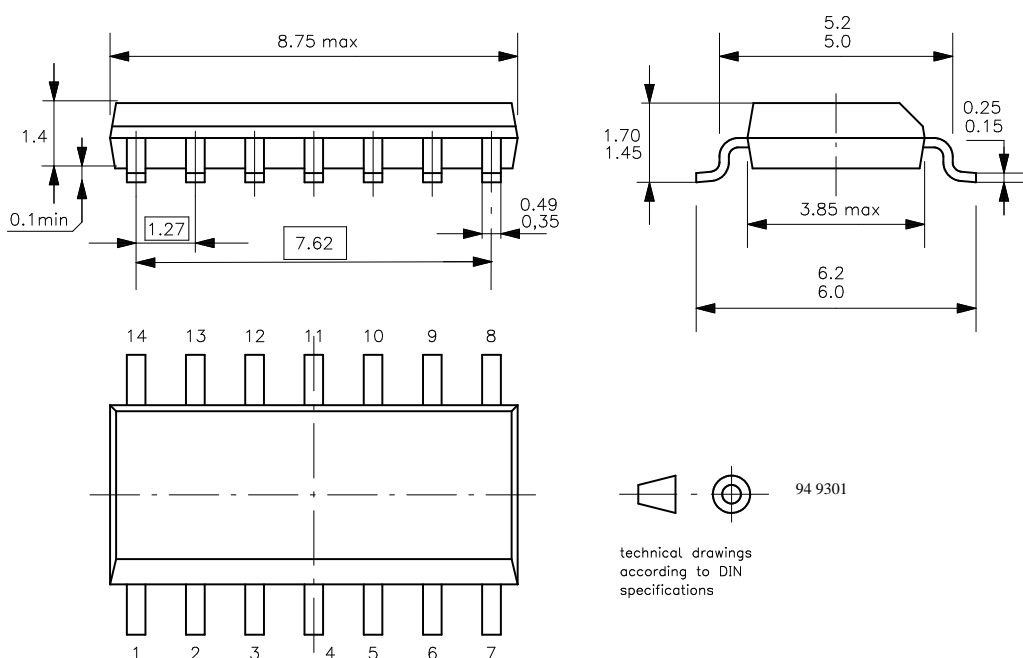

Figure 3. Schematic Application

Dimensions in mm

Package: SO 14



Ozone Depleting Substances Policy Statement

It is the policy of **TEMIC TELEFUNKEN microelectronic GmbH** to

1. Meet all present and future national and international statutory requirements.
2. Regularly and continuously improve the performance of our products, processes, distribution and operating systems with respect to their impact on the health and safety of our employees and the public, as well as their impact on the environment.

It is particular concern to control or eliminate releases of those substances into the atmosphere which are known as ozone depleting substances (ODSs).

The Montreal Protocol (1987) and its London Amendments (1990) intend to severely restrict the use of ODSs and forbid their use within the next ten years. Various national and international initiatives are pressing for an earlier ban on these substances.

TEMIC TELEFUNKEN microelectronic GmbH semiconductor division has been able to use its policy of continuous improvements to eliminate the use of ODSs listed in the following documents.

1. Annex A, B and list of transitional substances of the Montreal Protocol and the London Amendments respectively
2. Class I and II ozone depleting substances in the Clean Air Act Amendments of 1990 by the Environmental Protection Agency (EPA) in the USA
3. Council Decision 88/540/EEC and 91/690/EEC Annex A, B and C (transitional substances) respectively.

TEMIC can certify that our semiconductors are not manufactured with ozone depleting substances and do not contain such substances.

We reserve the right to make changes to improve technical design and may do so without further notice.

Parameters can vary in different applications. All operating parameters must be validated for each customer application by the customer. Should the buyer use TEMIC products for any unintended or unauthorized application, the buyer shall indemnify TEMIC against all claims, costs, damages, and expenses, arising out of, directly or indirectly, any claim of personal damage, injury or death associated with such unintended or unauthorized use.

TEMIC TELEFUNKEN microelectronic GmbH, P.O.B. 3535, D-74025 Heilbronn, Germany
Telephone: 49 (0)7131 67 2831, Fax number: 49 (0)7131 67 2423